

WIRE FUNCTION

LED Lighthouse:

HERO receives the POSITIVE (+) and GROUND (-) source through the OEM bulb socket plug. No extra wiring required. This lighthouse works for 2-function bulbs (F1: Tail/Park & F2: Stop/Turn) and 1-function bulbs (Stop, Tail, Turn or Reverse).

NOTE: To insert the vehicle integration connector into a 1-function bulb socket, detach Pin #2 using a wire cutter or a similar tool. (see figure 3)

8' sync/program cable

Use this cable to connect the lighthouse to the customer provided 12V ON/OFF switch 12V siren control system.

- RED wire: Flash/Warning function mode – Connect to POSITIVE (+) 12V
- BLUE wire is a multi-function programming cable:
 - Color selection: Apply to POSITIVE (+) 12V
 - Flash pattern selection: Apply to GROUND (-)

Synchronization

Connect the YELLOW wires among all HERO lighthouses that need to be synchronized. **Phase 1:** simultaneous flash, **Phase 2:** alternate flash

To program flash patterns or choose between the colors the lighthouse must be switched on.

Programming		
To select	Color options	Flash pattern
Blue Wire	Apply to POSITIVE (+)	Apply to GROUND (-)
0 - 1 sec.	Next color/pattern	
1 - 3 sec.	Previous pattern	
3 - 5 sec.	Back to Default pattern #1	
> 5 sec.	Last pattern	

ATTENTION: If your HERO does not light up, unplug the bulb socket connector invert it 180° and reinsert into the bulb socket again. (Reason: Halogen bulbs can be inserted both ways, LED devices just one way. The lighthouse is protected against reverse polarity. → No worries, inserting it the wrong way will not harm the lighthouse electronics.)

FLASH PATTERN

#FP	Single-Color	Multi-Color
1-Default	Quad 150 Hz, Phase 1	Quad 150 Hz, Phase 1
2	Quad 150 Hz, Phase 2	Quad 150 Hz, Phase 2
3	Single 75 Hz, Phase 1	Single 75 Hz, Phase 1
4	Single 75 Hz, Phase 2	Single 75 Hz, Phase 2
5	Single 120 Hz, Phase 1	Single 120 Hz, Phase 1
6	Single 120 Hz, Phase 2	Single 120 Hz, Phase 2
7	Single 375 Hz, Phase 1	Single 375 Hz, Phase 1
8	Single 375 Hz, Phase 2	Single 375 Hz, Phase 2
9	Double 75 Hz, Phase 1	Double 75 Hz, Phase 1
10	Double 75 Hz, Phase 2	Double 75 Hz, Phase 2
11	Double 120 Hz, Phase 1	Double 120 Hz, Phase 1
12	Double 120 Hz, Phase 2	Double 120 Hz, Phase 2
13	Triple 75 Hz, Phase 1	Triple 75 Hz, Phase 1
14	Triple 75 Hz, Phase 2	Triple 75 Hz, Phase 2
15	Quad 75 Hz, Phase 1	Quad 75 Hz, Phase 1
16	Quad 75 Hz, Phase 2	Quad 75 Hz, Phase 2
17*	2x Double Flash, 2x Quad Flash	
18*	4x Single Flash, 2x Triple Flash	
19*	Modul Flash sim.	
20*	Steady burn	

* It is not possible to sync of 2 HEROs if one is programmed on single color and the other one on dual color.

GENERAL INFORMATION:

When the driver applies the brake or activates the turn indicator, the STOP & TURN function will always override the warning function. As soon as the driver releases the brake/turn indicator, the lighthouse returns to flash mode.

WARNING OPTIONS

Color 1	Green	
Color 2	Amber	
Color 3	Clear	
Color 4	Amber	
Color 1 & Color 4	Green	Amber
Color 2 & Color 3	Amber	Clear
Color 1 & Color 3	Green	Clear
Color 3 & Color 4	Amber	Clear

INSERT VEHICLE INTEGRATION CONNECTOR INTO A 1-FUNCTION BULB SOCKET (figure 3)

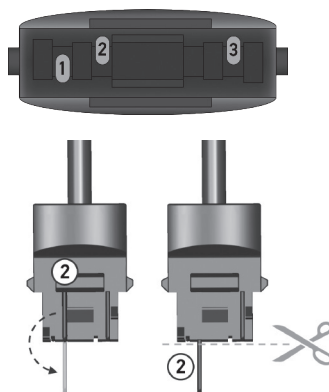

COMPLETED ASSEMBLY



WARNINGS

Warnings for the installer:

Do not attempt to install this lighthouse without the LED indicator control unit connected. The installer is responsible for ensuring that the installation and operation of this product will not interfere with the operation or efficiency of vehicle equipment.

Warnings to users:

HELLA's emergency vehicle warning devices are to alert other operators and pedestrians to the presence of emergency vehicles and personnel. The use of this or any other HELLA emergency warning device does not guarantee the right-of-way or that others will properly respond to the emergency warning signal. Always proceed with caution when entering an intersection, driving against traffic, driving at high speed. Test your Emergency vehicle warning devices daily to ensure that it is operating to standard. Full understanding of Emergency vehicle warning device laws and regulations should be obtained.

Specification & technical data:

The lighthouse is positioned directly in the headlight's original bulb socket opening. Its fixation is realized with vehicle specific adapter bezels. These adapter bezels are designed to place the lighthouse in the exact same spot ("focal point") as the original bulb.



HELLA Automotive Sales Inc.
201 Kelly Drive Peachtree City,
Georgia 30269 USA

HELLA KGaA Hueck Co.
Rixbecker Strasse 75
59552 Lippstadt/Germany
www.hella.com

For customer support:
Email: hero.usa@hella.com
Phone: (770)631-7500

Also visit:
www.myhellalights.com
www.hellaHD.com



HERO

HELLA UNDERCOVER HIDEAWAY

UNDERCOVER HIDEAWAY
INSTALLATION GUIDE

SAFETY FIRST

This guide provides all necessary information for your HELLA HERO to be installed and used safely. Before starting make sure the installation technician and operator reads this manual completely to avoid serious injury or damage during installation.

- Do not install this product unless you are an installer with professional understanding of automotive electronics, systems and procedures.
- If Drilling holes is necessary during installation be sure the area is free from all other vehicle equipment to avoid damage while drilling. Smooth any rough edges after drilling and remove all metal remains. Grommets should be installed into all wire passing holes.
- Do not install equipment or wiring in the air bag deployment area. Anything installed in the air bag deployment area can cause serious personal injury or death. The Installer assumes full responsibility in determining the correct mounting location in keeping with the highest safety standards to all passengers inside the vehicle.
- When pairing a remote device, make sure to install the control in an area that is safe for the vehicle and the control under all driving conditions.
- Avoid prolonged direct eye contact with the LED's. Momentary blindness and/or eye damage could result.
- Do not use cleaning chemicals on the lens to avoid premature lens cracking and discoloration.
- Inspect the working condition of this product on a regular basis to ensure proper performance.
- Incorrect installation of parts and/or hardware will affect the product warranty.

HERO ASSEMBLY

Pre-install assembly: Mount the vehicle specific adapter bezel to the lighthouse.

Step 1: Take adapter labeled "1" and place it over the raised rectangular alignment guide of the LED lighthouse.

Step 2: Take adapter "2" and attach it to adapter "1". Make sure the adapters are locked/seated properly around the HERO base.

Step 3: Pull the rubber gasket over the LED lighthouse all the way down until the gasket sits flat against the base to create a weather resistant seal. Please note, there are two sizes provided. Install the one, that properly fits over the adapter installed in the step above.

Step 4: Attach the 8' sync/program cable to the female inline connector of the LED lighthouse.

Step 5: Connect the HERO vehicle integration cable to the white male inline connector.

IMPORTANT: Do not install the HERO lighthouse without the vehicle integration cable.

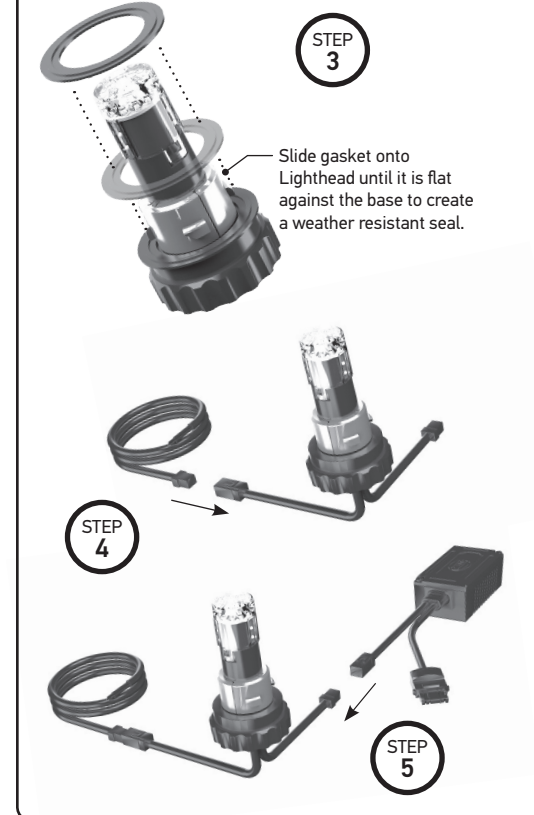
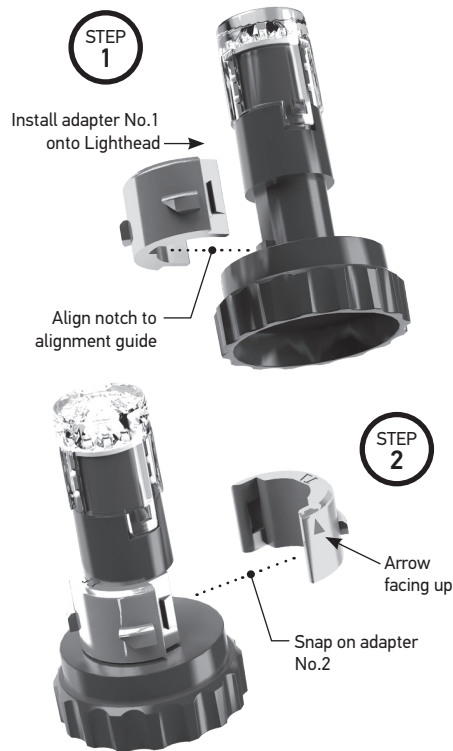

INSTALL INTO VEHICLE

Step 6: Remove the OEM bulb socket out of the head-/taillight chamber by twisting it counter clockwise.

Step 7: Unplug the original Halogen/Incandescent bulb from the OEM socket. **(figure 1)**

Step 8: Take the connector of the vehicle integration cable (B) and insert it into the OEM bulb socket base. **(figure 2)**

Step 9: Affix the module/box on the integration cable to the vehicle's body or any other metal surface.

CAUTION: During operation the module will get very hot (up to 70°C/160°F). Keep flammable materials in a safe distance (1-2" minimum) to prevent damage of other components.

Step 10: Take the pre-assembled HERO and twist it clockwise into the head/taillight opening for the OEM bulb position. Make sure that the Lighthouse is seated properly to create a tight seal.

NOTE: The install of the HERO lighthouse into a Chevy Tahoe front turn signal chamber requires slightly different steps 7 & 8. Please follow the QR code below for a detailed install description. **(Continue reading on other side)**

TIP: We recommend using "Dielectric Grease" to seal the removed bulb socket and protect the contacts from water and corrosion.

SCOPE OF DELIVERY

- A) LED lighthouse
- B) HERO vehicle integration cable
- C) 8' sync/program cable
- D) Rubber gaskets (G1 - Ø 31mm, G2 - Ø 42mm)
- E) Vehicle specific adapter bezels (NOT INCLUDED)



CHEVY TAHOE INSTALLATION

